



The Q.series has been designed for demanding measurements found in today's most industrial measuring and testing environments. The range of applications starts from single stand-alone solutions up to networked multi-channel applications in the field of component testing, engine testing, process performance testing and structural monitoring.

The range and flexibility of the modules allows an optimized solution for each single task: Dynamic signal acquisition up to 100 kHz, in/outputs for all types of signals, galvanic isolation of in/outputs, multi-channel solutions, high density packaging and intelligent signal conditioning.

Data exchange between Test Controller and automation level is communicated via Ethernet TCP/IP or fieldbus system EtherCAT. Further Ethernet-based industrial standards are in preparation.

### Most important features:

- **Connection of up to 32 Q.bloxx modules**  
via 4 UARTS, Baud rate up to 24 MBaud each UART
- **Recording of up to 256 variables**  
real format 4 Byte
- **Synchronization and time stamp of measurement values**
- **Ethernet interface for configuration and data output**  
FTP, TCP/IP, UDP
- **FTP Server and FTP Client functionality**  
configurable function
- **Optional fieldbus interface**  
EtherCAT according specification ETG
- **High data rate over Ethernet**  
128 real variables with 1 kHz (block transfer)  
16 real variables with 10 kHz (block transfer)  
64 real variables with 300 Hz (online)
- **Data buffer memory dyn. 12 MByte, stat. 128 MByte**  
Data buffer at block transfer of measurements
- **PAC functionality with extensive function block library**  
Sequences, data logger, PID-controller, transfer functions, mathematic, numeric, Boolean combinations, functions generator
- **Galvanic isolation**  
of power supply and interfaces
- **Electromagnetic Compatibility**  
according EN 61000-4 and EN 55011
- **Power supply 10...30 VDC**
- **DIN rail mounting (EN 50022)**

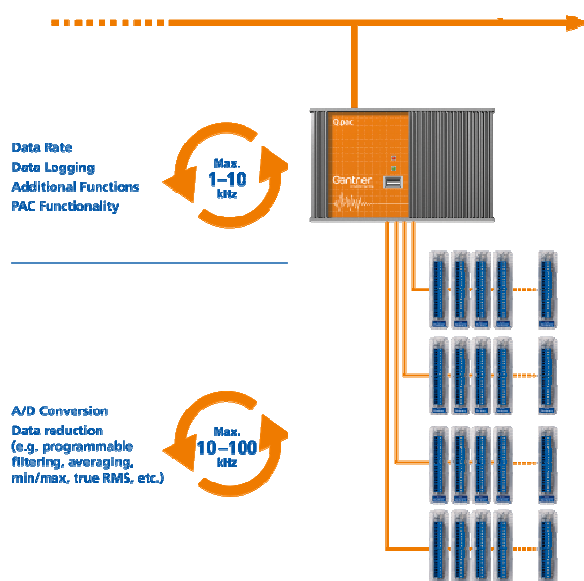

**Ethernet  
TCP / IP**

**EtherCAT**  
Technology Group

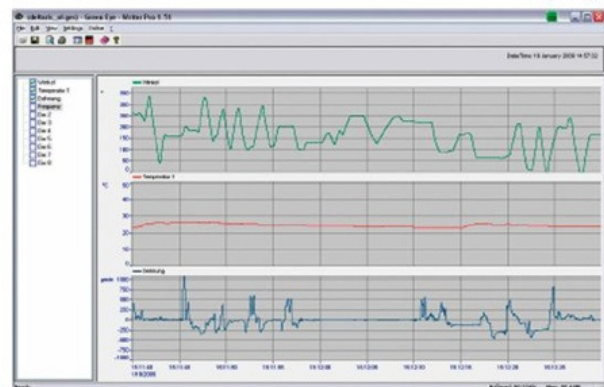



<b>Host Interface Ethernet</b>	
Protocols	TCP/IP, UDP, PING, ASCII, Modbus TCP/IP
Services	DHCP, FTP-Server, FTP-Client, e-Mail-Send-Client (SMTP)
Baud rate	10/100 Mbps
Data rate	max. 800 kByte/s
Number of simultaneous Clients	10
Isolation voltage	500 V
<b>Host Interface EtherCAT (Q.pac EC only)</b>	
Standard	Ethernet
Number of channels	256 Byte data
Baud rate	100 Mbps
Cycle time	≥100 µs
Isolation voltage	500 V
<b>Host Interface USB</b>	
Version	USB 2.0
Data rate	Typ. 100 kByte/s
Devices	Data storage, formatted with FAT oder FAT 32
<b>Slave Interfaces RS 485</b>	
Number of interfaces	4
Standard	RS 485
Data format	8E1
Protocol	Local Bus
Baud rate	9,6 kbps up to 24 Mbps
Connectable devices	max. 16 modules at one UART line
Isolation voltage	500 V
<b>Digital Inputs</b>	
Function	fixed definition
Input voltage	max. 30 VDC
Input current	max. 1,5 mA
Upper switching threshold	>3,5 V (high)
Lower switching threshold	<1,0 V (low)
<b>Digital Outputs</b>	
Function	fixed definition
Type of output	Open Drain p-Kanal MOSFET
Output voltage	max. 30 VDC
Output current	max. 100 mA



## Q.pac DL / EC

Test Controller

<b>Data Memory</b>		
RAM	12 MByte, cycle buffer	
Flash	128 MByte	
<b>Operating system independent</b>		
Standardized Interface	Ethernet (FTP/Berkeley-Socket)	
<b>Power Supply</b>		
Power supply	10 bis 30 VDC, over voltage and overload protection	
Power consumption	approx. 4,5 W	
<b>Environmental</b>		
Operating temperature	-20 °C to +60 °C	
Storage temperature	-40 °C to +85 °C	
Relative humidity	5 % to 95 % at 50 °C, non condensing	
<b>Mechanical</b>		
Case	Aluminium	
Dimensions (W x H x D)	(175 x 110 x 55) mm	
Weight	700 g	
Mounting	DIN EN rail	
<b>PAC Functionality</b>		
Performance examples	no. of channels at data rate	
<b>Function</b>	<b>Rate 1000/s</b>	<b>Rate 500 Hz/s</b>
PID controller	20	44
FIR Filter 100 coefficients	4	20
Alarm and limit control	30	60
Linearization, 16 pole interpolation	20	40
Arithmetic	90	180

Programming Tool test.con

Using test.con for programming of the PAC-function in a graphical way:

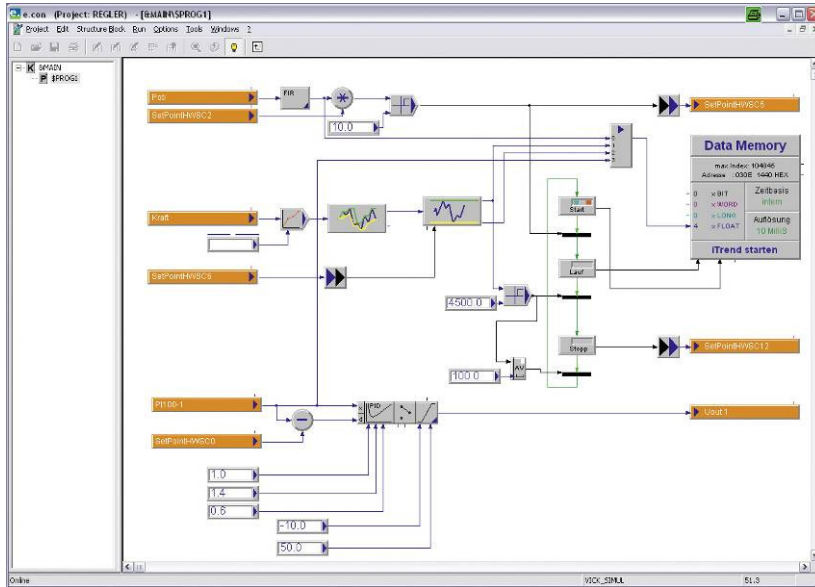

- Project Libraries
- Advanced System Functions (V1.0)
  - Archive (V 5.0)
  - Arithmetic (Time) V1.0
  - Arithmetic (Word, Long, Float) (V4.0)
  - Comparison (Time) V1.0
  - Control elements (V0.0)
  - Controller (Float)
  - Converter (Bit, Byte, Word, Long, Float, Text) (V4.0)
  - Converter (Time) V1.0
  - Counter (Word)
  - Device Data Access Functions
    - Read access
    - Write access
  - Digital Filter (V1.0)
  - Edge detection (Bit)
  - Extended SFB
  - Flipflops (Bit)
  - Function generator (V 3.0)
  - Global Variables and References (extended)
  - Logic (Bit)
  - Memory (V1.0)
  - Numeric (Float)
  - Operatingsystem-Functions (V1.0)
  - Parameter (Time) V1.0
  - Parameter blocks (V 1.0)
  - Selection and comparison (Byte, Word, Long, Float)
    - Comparator
    - Limit indicator
    - Limiter
    - Maximum
    - Minimum
    - Multiplexer
    - Switch
  - Sequence blocks
    - Joining transition
    - Pre-set
    - Splitting transition
    - Step
    - Transition
  - Shift and rotate (Byte, Word, Long)
  - Signal generators (V1.0)
  - Signal processing (V1.0)
  - Standard
  - Standard transmission terms (Float)
  - String functions
  - Timer (Float)
  - Timer (Time) V2.0
  - Visualization blocks (Time) V2.0
  - Visualization Blocks (V6.0)

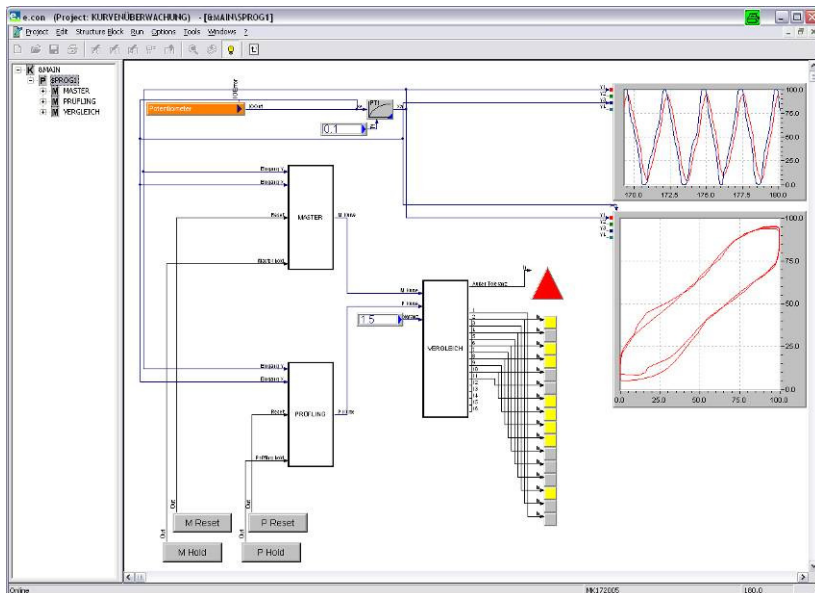

Valid from September 15<sup>th</sup> 2009. Specification subject to change without notice  
DB\_Q.pac\_E\_10.doc