



## Q.raxx A106-8 *slimline* RS / EC

Universal Bridge Measurement System

The Q.raxx *slimline* product is based on the standardized 19" technology, one rack unit (1 U) and is designed for measurements with a high level of flexibility, reliability and accuracy in the field of stationary testing and assembly.

The EC version includes a Test Controller that offers the user a powerful solution with PAC functionality, synchronized data acquisition, sequencing, mathematics, combinations a Ethernet TCP/IP interface as well as a EtherCAT fieldbus. It is possible to connect three *slimline* basic units to the Test Controller of a *slimline* EC unit.

Beside the pre-defined standard versions customized systems regarding numbers of channels, kind of measurement inputs/connectable sensors as well as the required connectors are configurable.

This modularity permits to design an optimized individual solution for any application. Further it is possible to mix different product lines like Q.raxx, Q.bloxx within Q.series.

### Most important features:

- **8 analog input channels for bridges**  
strain gauge and inductive bridges (full, half, quarter), LVDT, RVDT
- **DC and carrier frequency principle selectable**  
DC bridge excitation, AC 600 Hz and 4.8 kHz bridge excitation
- **Fast high accuracy digitalization**  
24 bit ADU, 10 kHz sample rate per channel
- **Signal conditioning**  
linearization, digital filter, average, scaling, min/max storage, arithmetic, alarm
- **1 analog output per channel**  
voltage  $\pm 10$  V, 10 kHz
- **Galvanic isolation**  
of analog in/out, power supply and interface,  $V_{iso}$  500 VDC
- **Power supply 10...30 VDC**

### With embedded Test Controller (version EC):

- **Optional fieldbus interface EtherCAT**  
EtherCAT according specification ETG, 256 read and 256 write variable with 10 kHz
- **Ethernet interface for configuration and data output**  
FTP, TCP/IP, UDP
- **FTP Server and FTP Client functionality**  
configurable function
- **High data rate over Ethernet**  
16 real variables with 10 kHz (block transfer)  
64 real variables with 300 Hz (online)
- **Data buffer memory dyn. 16 MByte (RAM), stat. 128 MByte (flash)**  
data buffer at block transfer of measurements
- **Connection of additional racks to the Test Controller**  
up to 3 *slimline* racks without Test Controller can be connected to a *slimline* EC system with embedded controller

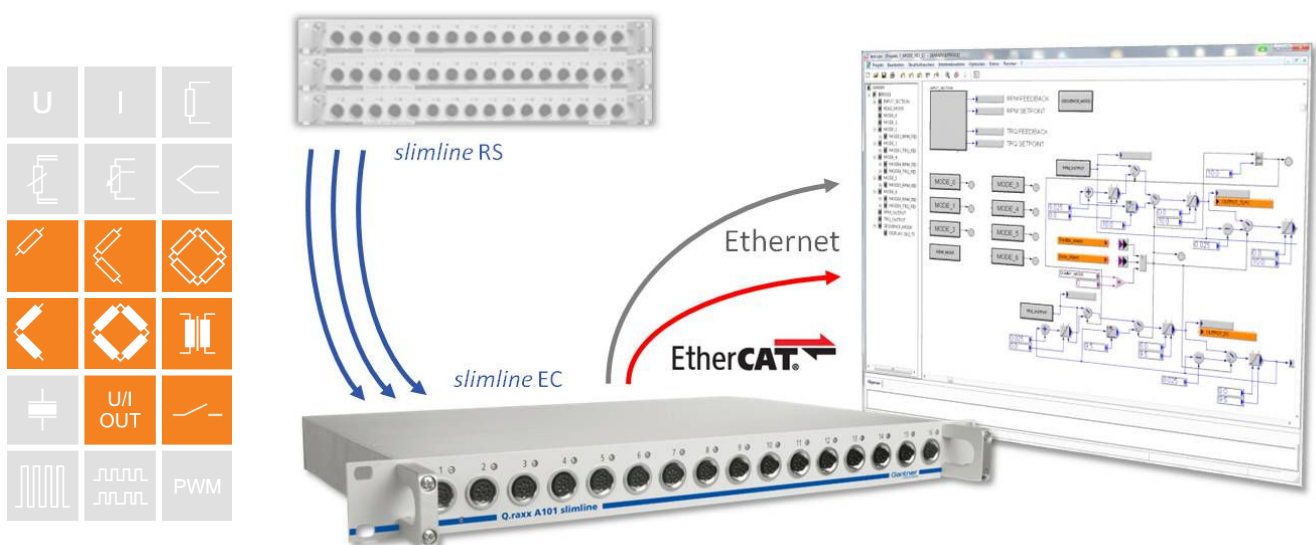



# Q.raxx A106-8 *slimline* RS / EC

Universal Bridge Measurement System

Connection Diagram Q.raxx *slimline* EC

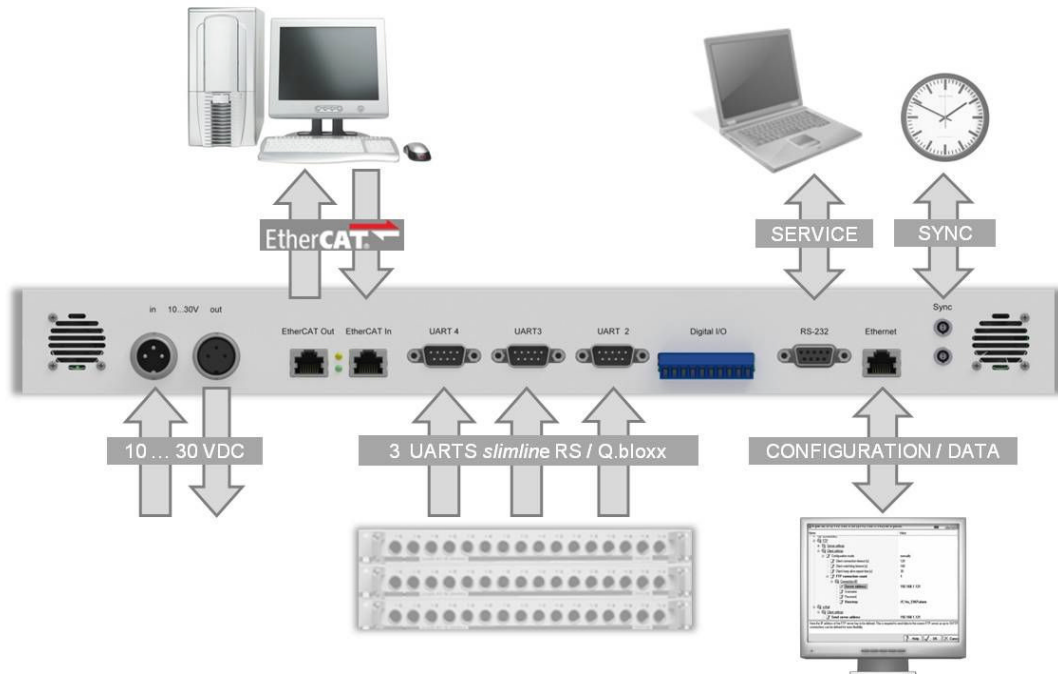

Analog Inputs			
Number	8		
Accuracy	0.05 % typical		
	0.1 % in controlled environment <sup>1</sup>		
	0.5 % in industrial area <sup>2</sup>		
Repeatability	0.003 % typical (within 24 h)		
Input resistance	>10 MΩ		
Isolation voltage	500 VDC channel to channel to power supply to interface <sup>3</sup>		
	<b>DC Mode</b>	<b>600 Hz Carrier Mode (AC)</b>	<b>4.8 kHz Carrier Mode (AC)</b>
Sensor type	resistive full and half bridge (5/6 wire), quarter bridge with completion (3 wire)	resistive full and half bridge (5/6 wire), quarter bridge with completion (3 wire)	resistive full and half bridge (5/6 wire), quarter bridge with completion (3 wire) inductive full and half bridges, LVDT and RVDT sensors
Permitted sensor cable length	<300 m	<300 m	<100 m
Sensor connection	with or without sense leads for compensation of cable influences full bridge 4 or 6 wire half bridge 3 or 5 wire quarter bridge 3 wire in combination with completion terminal 120 Ω or 350 Ω		

<sup>1</sup> according EN 61326: 1997, appendix B

<sup>2</sup> according EN 61326: 1997, appendix A

<sup>3</sup> noise pulses up to 1000 VDC, permanent up to 250 VDC



## Q.raxx A106-8 slimline RS / EC

Universal Bridge Measurement System

Sensor excitation (selectable)	DC: 5 VDC	CF: 5 Veff	DC: 2.5 VDC	CF: 2.5 Veff
Permitted sensor resistance	>300 Ω	>300 Ω	>100 Ω	>100 Ω
Measuring range	±1.25 mV/V	±1.25 mV/V	±2.5 mV/V	±2.5 mV/V
	±2.5 mV/V	±2.5 mV/V	±5 mV/V	±5 mV/V
	±25 mV/V	±25 mV/V	±50 mV/V	±50 mV/V
	±50 mV/V	±50 mV/V	±100 mV/V	±100 mV/V
	±100 mV/V	±100 mV/V	±200 mV/V	±200 mV/V
	±250 mV/V	±250 mV/V	±500 mV/V	±500 mV/V
Temperature influence on zero (range 2.5 mV/V)	±500 mV/V	±500 mV/V	±1000 mV/V	±1000 mV/V
	<1 μV / 10 K	<1 μV / 10 K	<1 μV / 10 K	<1 μV / 10 K
Temperature influence on sensitivity (measuring value)	<0.05 % / 10 K	<0.05 % / 10 K	<0.05 % / 10 K	<0.05 % / 10 K
Long term drift	<1 μV/V / 24 h	<0.5 μV/V / 24 h	<1 μV/V / 24 h	<0.5 μV/V / 24 h
	<2.5 μV / V/8000h	<1.25 μV/V / 8000 h	<2.5 μV / V/8000h	<1.25 μV/V / 8000 h
Linearity Error	<0.02 % f.s.			
Noise voltage at 10 Hz	<0.3 μV/V			
Noise voltage at 100 Hz	<1 μV/V			
<b>Analog Digital Conversion</b>				
Resolution	24 bit			
Sample rate	10 kHz			
Conversion method	Sigma-Delta (group delay time 600 μs)			
Anti-aliasing Filter	DC: 1 kHz 5 <sup>th</sup> order	4.8 kHz CF: 1 kHz 5 <sup>th</sup> order	600 Hz CF: 100 Hz, 5 <sup>th</sup> order	
Digital filter	IIR, low pass, high pass, band pass, 4 <sup>th</sup> order, 1 Hz up to 1 kHz in steps 1, 2, 5			
Averaging	configurable or automated according the selected data rate			
<b>Analog Outputs</b>				
Number	8 voltage outputs			
Accuracy	0.02 %			
DAU resolution	16 bit			
Sample rate	10 kHz			
Output voltage	±10 VDC			
Perm. load resistance	>2 kΩ			
Temperature influence	on zero		on sensitivity	
	<1 mV / 10 K		<0.05 % / 10 K	
Noise voltage in the range of	<10 mV at 1 kHz		<2 mV at 10 Hz	
Long term drift	<1 mV / 24h			



## Q.raxx A106-8 *slimline* RS / EC

Universal Bridge Measurement System

<b>Digital Inputs (<i>slimline</i> EC)</b>	
Function	fixed definition
Input voltage	max. 30 VDC
Input current	max. 1.5 mA
Upper switching threshold	>3.5 V (high)
Lower switching threshold	<1.0 V (low)
<b>Digital Outputs (<i>slimline</i> EC)</b>	
Function	fixed definition
Type of output	Open Drain p-Kanal MOSFET
Output voltage	max. 30 VDC
Output current	max. 100 mA
<b>Communication Interface (<i>slimline</i> RS) to connect to a Test Controller</b>	
Standard	RS-485, 2-wire
Data format	8e1
Protocols	Local-Bus: 115200 bps up to 48 Mbps Modbus-RTU, ASCII: 19200 bps up to 115200 bps
<b>Host Interface Ethernet (<i>slimline</i> EC only)</b>	
Protocols	TCP/IP, UDP, PING, ASCII, Modbus TCP/IP
Services	DHCP, FTP-Server, FTP-Client, e-Mail-Send-Client (SMTP)
Baud rate	10/100 Mbps
Data rate	max. 800 kByte/s
Number of simultaneous Clients	10
Isolation voltage	500 V
<b>Host Interface EtherCAT (<i>slimline</i> EC only)</b>	
Standard	Ethernet
Number of channels	1024 Byte read and write data
Baud rate	100 Mbps
Cycle time	≥100 µs
Isolation voltage	500 V



## Q.raxx A106-8 *slimline* RS / EC

Universal Bridge Measurement System

<b>Slave Interfaces RS 485 (<i>slimline</i> EC only) to connect further <i>slimline</i> RS, see Connection Diagram</b>		
Number of interfaces	3	
Standard	RS 485	
Data format	8E1	
Protocol	Local Bus	
Baud rate	9.6 kbps up to 24 Mbps	
Isolation voltage	500 V	
<b>Data Memory (<i>slimline</i> EC)</b>		
RAM	16 MByte (optional 90 MByte), cycle buffer	
Flash	128 MByte	
<b>Synchronization of a Multi Device System (<i>slimline</i> EC)</b>		
Interface	RS485 Standard	
Mode	Master Slave principle, IRIG standard	DCF77, AFNOR etc, GPS over IRIG standard
	GPS NMEA over RS232	SNTP over Ethernet
<b>Power Supply</b>		
Power supply	10 bis 30 VDC, Überspannungs- und Verpolungsschutz	
Power consumption <i>slimline</i> RS	approx. 10 W	
Power consumption <i>slimline</i> EC	approx. 15 W	
Influence of the voltage	<0,001 %/V	
<b>Mechanical</b>		
Type	19" Standard, 1 unit	
Dimensions (W x H x D)	(444 x 44 x 260) mm	
Protection system	IP20	
<b>Environmental</b>		
Operating temperature	-20°C up to +60°C	
Storage temperature	-40°C up to +85°C	
Relative humidity	5 % up to 95 % at 50°C, non condensing	
<b>PAC Functionality (<i>slimline</i> EC)</b>		
Cycle time	≥1 ms	
Processing	cyclic or synchronized with data acquisition	



Programming Tool test.con

Using test.con for programming of the PAC-function in a graphical way:

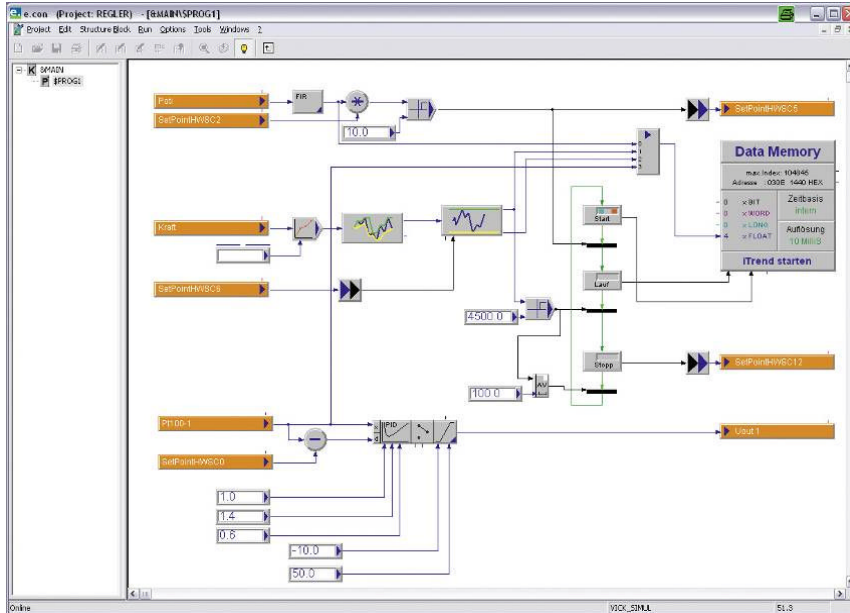

- Project Libraries
- Advanced System Functions (V1.0)
  - Archive (V 5.0)
  - Arithmetic (Time) V1.0
  - Arithmetic (Word, Long, Float) (V4.0)
  - Comparison (Time) V1.0
  - Control elements (V0.0)
  - Controller (Float)
  - Converter (Bit, Byte, Word, Long, Float, Text) (V4.0)
  - Converter (Time) V1.0
  - Counter (Word)
  - Device Data Access Functions
    - Read access
    - Write access
  - Digital Filter (V1.0)
  - Edge detection (Bit)
  - Extended SFB
  - Flipflops (Bit)
  - Function generator (V 3.0)
  - Global Variables and References (extended)
  - Logic (Bit)
  - Memory (V1.0)
  - Numeric (Float)
  - Operatingsystem-Functions (V1.0)
  - Parameter (Time) V1.0
  - Parameter blocks (V 1.0)
  - Selection and comparison (Byte, Word, Long, Float)
    - Comparator
    - Limit indicator
    - Limiter
    - Maximum
    - Minimum
    - Multiplexer
    - Switch
  - Sequence blocks
    - Joining transition
    - Preset
    - Splitting transition
    - Step
    - Transition
  - Shift and rotate (Byte, Word, Long)
  - Signal generators (V1.0)
  - Signal processing (V1.0)
  - Standard
  - Standard transmission terms (Float)
  - String functions
  - Timer (Float)
  - Timer (Time) V2.0
  - Visualization blocks (Time) V2.0
  - Visualization Blocks (V6.0)

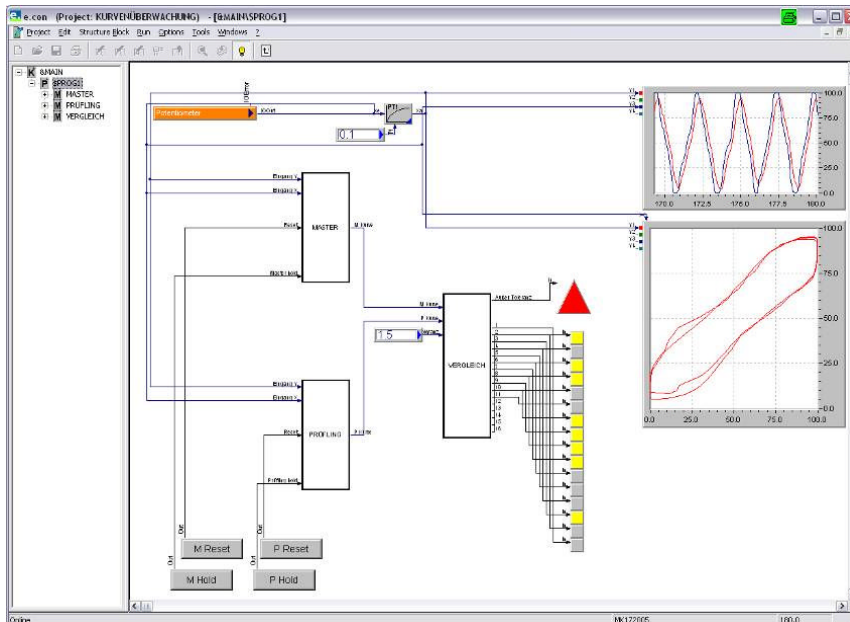

Warm Up Time

All declarations are valid after a warm up time of 45 minutes.

Valid from January 2011. Specification subject to change without notice DB\_Q.raxx\_A106-8SL\_E\_20.docx