



Q.raxx A107-16 slimline RS / EC

Universal Measurement System

The Q.raxx *slimline* product is based on the standardized 19" technology, one rack unit (1 U) and is designed for measurements with a high level of flexibility, reliability and accuracy in the field of stationary testing and assembly.

The EC version includes a Test Controller that offers the user a powerful solution with PAC functionality, synchronized data acquisition, sequencing, mathematics, combinations a Ethernet TCP/IP interface as well as a EtherCAT fieldbus. It is possible to connect three *slimline* basic units to the Test Controller of a *slimline* EC unit.

Beside the pre-defined standard versions customized systems regarding numbers of channels, kind of measurement inputs/connectable sensors as well as the required connectors are configurable.

This modularity permits to design an optimized individual solution for any application. Further it is possible to mix different product lines like Q.raxx, Q.bloxx within Q.series.

Most important features:

- **16 universal analog input channels**
voltage, current, resistance, potentiometer, Pt100, Pt1000, thermocouples, measuring bridges
- **Fast high accuracy digitalization**
24 bit ADC, 10 kHz sample rate per channel
- **Signal conditioning**
Linearization, digital filter, average, scaling, min/max storage, RMS, arithmetic, alarm
- **Galvanic isolation**
Kanal II Kanal II Versorgung II Schnittstelle, V_{iso} 500 VDC
- **Galvanic isolation**
of analog in/out, power supply and interface, V_{iso} 500 VDC
- **Power supply 10...30 VDC**

With embedded Test Controller (version EC):

- **Optional fieldbus interface EtherCAT**
EtherCAT according specification ETG, 256 read and 256 write variable with 10 kHz
- **Ethernet interface for configuration and data output**
FTP, TCP/IP, UDP
- **FTP Server and FTP Client functionality**
configurable function
- **High data rate over Ethernet**
16 real variables with 10 kHz (block transfer)
64 real variables with 300 Hz (online)
- **Data buffer memory dyn. 16 MByte (RAM), stat. 128 MByte (flash)**
data buffer at block transfer of measurements
- **Connection of additional racks to the Test Controller**
up to 3 *slimline* racks without Test Controller can be connected to a *slimline* EC system with embedded controller

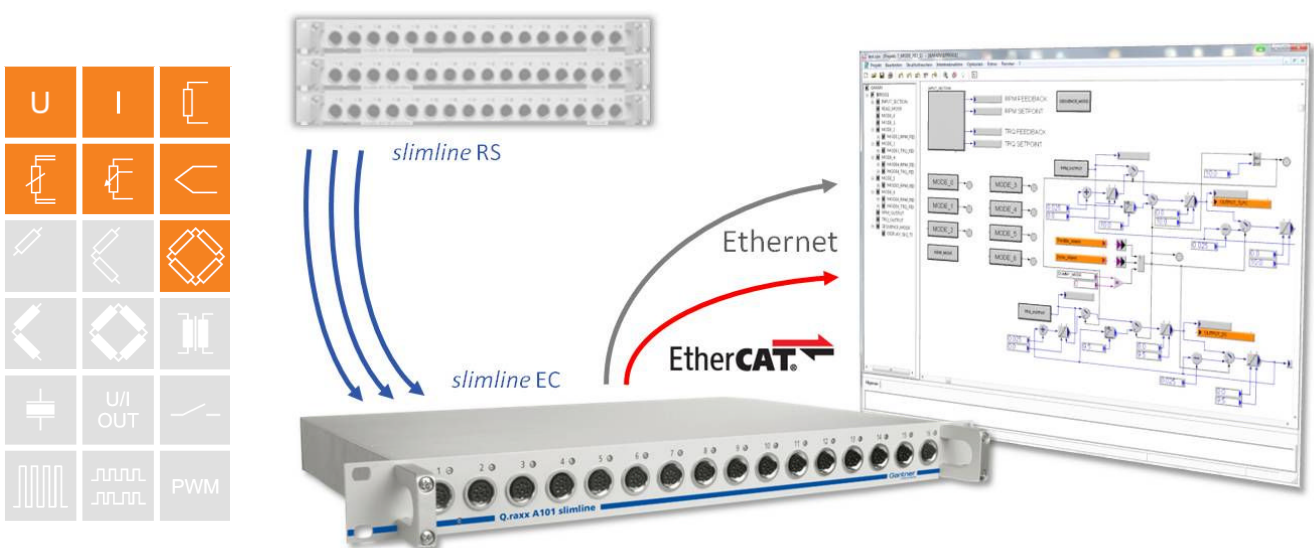



Q.raxx A107-16 *slimline* RS / EC

Universal Measurement System

Connection Diagram Q.raxx *slimline* EC

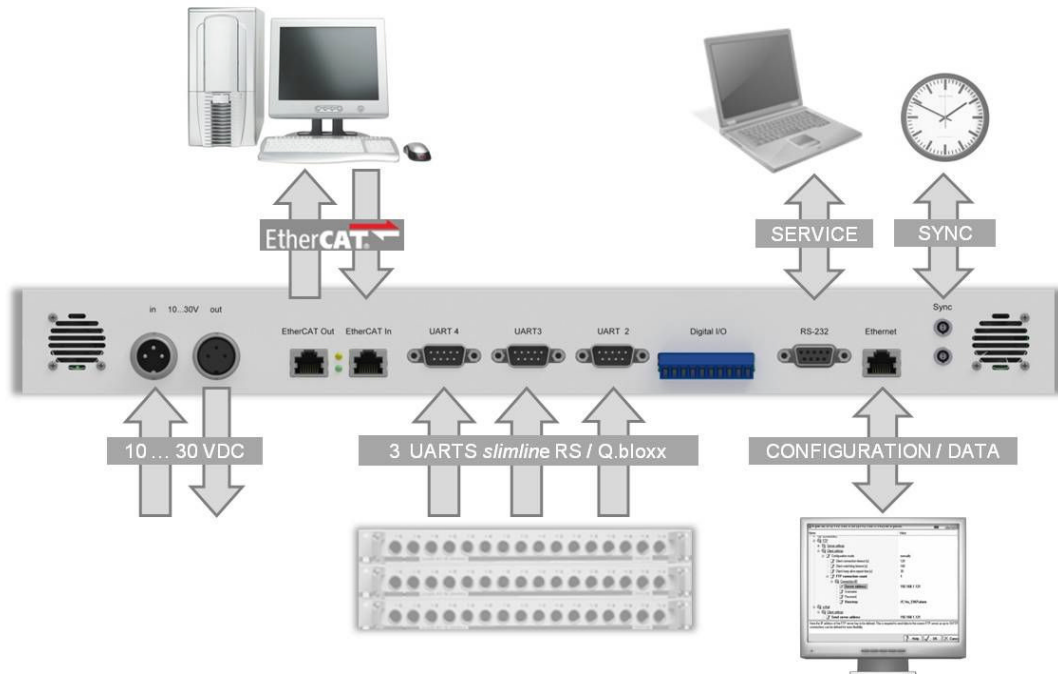

Analog Inputs			
Number	16		
Accuracy	0.01 % typical		
	0.02 % in controlled environment ¹		
	0.05 % in industrial area ²		
Linearity error	0.01 % of the final value typical		
Repeatability	0.003 % typical (within 24 h)		
Isolation voltage	500 VDC channel to channel to power supply to interface ³		
Measurement Voltage	Range	max. Deviation	Resolution
	±10 V	±2 mV	1.2 µV
	±1 V	±0.2 mV	120 nV
	±100 mV	±20 µV	12 nV
Input resistance	>100 MΩ		
Long term drift	<10 µV / 24 h; <25 µV / 8000 h		range ±1 V
Temperature influence	on zero	on sensitivity	
	<1 µV / 10 K	<0.05 % / 10 K	
Signal-noise-ratio	> 90 dB at 1 kHz	>120 dB at 1 Hz	

¹ according EN 61326: 1997, appendix B

² according EN 61326: 1997, appendix A

³ noise pulses up to 1000 VDC, permanent up to 250 VDC



Q.raxx A107-16 slimline RS / EC

Universal Measurement System

Measurement Current	Range	max. Deviation	Resolution
(internal shunt 50 Ω)	±25 mA	±5 µA	3.0 nA
Long term drift	<0.2 µA/24 h; <0.5 µA/8000 h		
Temperature influence	on zero	on sensitivity	
	<0.1 µA / 10 K	<0.03 % / 10 K	
Measurement Resistance / RTD	Range	max. Deviation	Resolution
Resistance, 2-wire	100 kΩ	±100 Ω	12 mΩ
Resistance, 2- and 4-wire	4 kΩ	±1 Ω	0.5 mΩ
Resistance, 2- and 4-wire	400 Ω	±0.1 Ω	48 µΩ
Pt100, 2- and 4-wire	-200 up to +850°C	±0.25°C	0.2 m°C
Pt1000, 2- and 4-wire	-200 up to +850°C	±1°C	0.2 m°C
Temperature influence	on zero (range 400 Ω)	on sensitivity	
	<0.4 mΩ / 10 K ≅ 0.002°C / 10 K	<0.03 % / 10 K	
Measurement Potentiometer	Relative measurement		
Permitted potentiometer resistance	1 kΩ to 10 kΩ		
Long term drift	<0.02 % / 24 h, <0.05 % / 8000 h		
Temperature influence	on zero (range 1)	on sensitivity	
	<0.0001 / 10 K	<0.03 % / 10 K	
Measurement Bridge			
Accuracy class	0.05		
Bridge Type	full bridge, 4-wire connection, half and quarter bridge with completion terminal		
Sensor resistance	>100 Ω		
Supply	2.5 V nominal		
Measurement range	±2.5 mV/V	±50 mV/V	±500 mV/V
Temperature influence	on zero (range 2.5 mV/V)	on sensitivity	
	<1 µV/V / 10 K	<0.05 % / 10 K	
Long term drift	<1 µV/V / 24h; <2.5 µV/V / 8000 h		
Measurement Thermocouple	Whole range	-100°C...upper limit	
Type B	better than ±5°C	better than ±2.5°C	
Type E, J, K, L, T, U	better than ±1°C	better than ±0.5°C	
Type N	better than ±2°C	better than ±1°C	
Type R, S	better than ±3°C	better than ±1.5°C	
Input resistance	>100 MΩ		
Long term drift	<0.05 °C/24 h; 0.15 °C/8000 h		
Temperature influence	on zero	on sensitivity	
	<0.025°C / 10 K	<0.005% / 10 K	
Uncertainty cold junction compens.	<0.3°C		



Q.raxx A107-16 *slimline* RS / EC

Universal Measurement System

Analog/Digital-Conversion	
Resolution	24 bit
Sample rate	10 kHz, (measurement thermocouple 10 Hz)
Conversion method	Sigma-Delta (group delay time 600 µs)
Anti-aliasing filter	2 kHz, 5 th order
Digital filter	IIR, low pass, high pass, band pass, 4 th order, 1 Hz up to 1 kHz in steps 1, 2, 5
Averaging	configurable or automated according the selected data rate
Digital Inputs (<i>slimline</i> EC only)	
Function	fixed definition
Input voltage	max. 30 VDC
Input current	max. 1.5 mA
Upper switching threshold	>3.5 V (high)
Lower switching threshold	<1.0 V (low)
Digital Outputs (<i>slimline</i> EC only)	
Function	fixed definition
Type of output	Open Drain p-Kanal MOSFET
Output voltage	max. 30 VDC
Output current	max. 100 mA
Communication Interface (<i>slimline</i> RS) to connect to a Test Controller	
Standard	RS-485, 2-wire
Data format	8e1
Protocols	Local-Bus: 115200 bps up to 48 Mbps Modbus-RTU, ASCII: 19200 bps up to 115200 bps
Host Interface Ethernet (<i>slimline</i> EC only)	
Protocols	TCP/IP, UDP, PING, ASCII, Modbus TCP/IP
Services	DHCP, FTP-Server, FTP-Client, e-Mail-Send-Client (SMTP)
Baud rate	10/100 Mbps
Data rate	max. 800 kByte/s
Number of simultaneous Clients	10
Host Interface EtherCAT (<i>slimline</i> EC only)	
Standard	Ethernet
Number of channels	1024 Byte read and write data
Baud rate	100 Mbps
Cycle time	≥100 µs
Isolation voltage	500 V



Q.raxx A107-16 *slimline* RS / EC

Universal Measurement System

Slave Interfaces RS 485 (<i>slimline</i> EC only) to connect further <i>slimline</i> RS, see Connection Diagram		
Number of interfaces	3	
Standard	RS 485	
Data format	8E1	
Protocol	Local Bus	
Baud rate	9.6 kbps up to 24 Mbps	
Connectable devices	max. 16 modules at one UART line	
Isolation voltage	500 V	
Data Memory (<i>slimline</i> EC only)		
RAM	16 MByte (optional 90 MByte), cycle buffer	
Flash	128 MByte	
Synchronization of a Multi Device System (<i>slimline</i> EC only)		
Interface	RS485 Standard	
Mode	Master Slave principle, IRIG standard	DCF77, AFNOR etc, GPS over IRIG standard
	GPS NMEA over RS232	SNTP over Ethernet
Power Supply		
Power supply	10 bis 30 VDC, Überspannungs- und Verpolungsschutz	
Power consumption <i>slimline</i> RS	approx. 10 W	
Power consumption <i>slimline</i> EC	approx. 15 W	
Influence of the voltage	<0,001 %/V	
Mechanical		
Type	19" Standard, 1 unit	
Dimensions (W x H x D)	(444 x 44 x 260) mm	
Protection system	IP20	
Environmental		
Operating temperature	-20°C up to +60°C	
Storage temperature	-40°C up to +85°C	
Relative humidity	5 % up to 95 % at 50°C, non condensing	
PAC Functionality (<i>slimline</i> EC only)		
Cycle time	≥1 ms	
Processing	cyclic or synchronized with data acquisition	



Q.raxx A107-16 slimline RS / EC

Universal Measurement System

Programming Tool test.con

Using test.con for programming of the PAC-function in a graphical way:

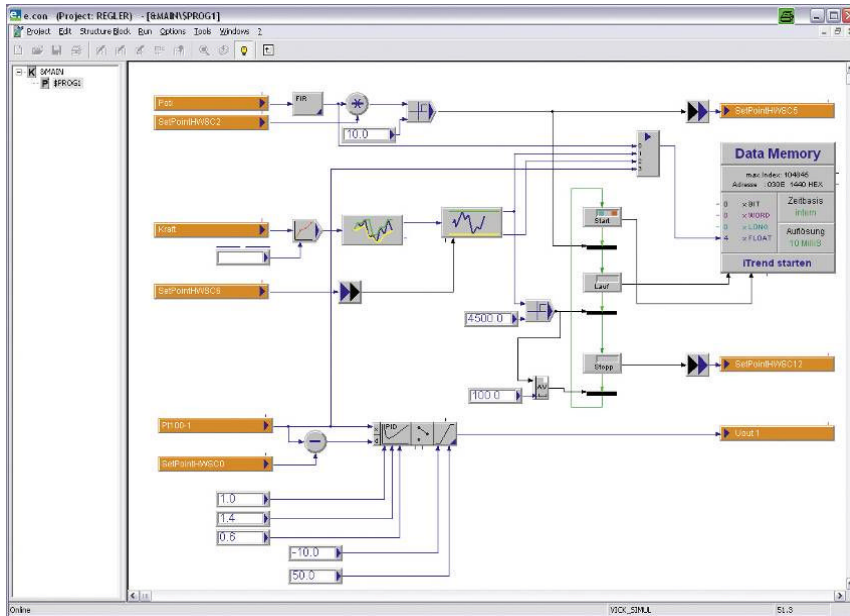

- Project Libraries
- Advanced System Functions (V1.0)
 - Archive (V 5.0)
 - Arithmetic (Time) V1.0
 - Arithmetic (Word, Long, Float) (V4.0)
 - Comparison (Time) V1.0
 - Control elements (V0.0)
 - Controller (Float)
 - Converter (Bit, Byte, Word, Long, Float, Text) (V4.0)
 - Converter (Time) V1.0
 - Counter (Word)
 - Device Data Access Functions
 - Read access
 - Write access
 - Digital Filter (V1.0)
 - Edge detection (Bit)
 - Extended SPB
 - FlipFlops (Bit)
 - Function generator (V 3.0)
 - Global Variables and References (extended)
 - Logic (Bit)
 - Memory (V1.0)
 - Numeric (Float)
 - Operatingsystem-Functions (V1.0)
 - Parameter (Time) V1.0
 - Parameter blocks (V 1.0)
 - Selection and comparison (Byte, Word, Long, Float)
 - Comparator
 - Limit indicator
 - Limitier
 - Maximum
 - Minimum
 - Multiplexer
 - Switch
 - Sequence blocks
 - Joining transition
 - Preset
 - Splitting transition
 - Step
 - Transition
 - Shift and rotate (Byte, Word, Long)
 - Signal generators (V1.0)
 - Signal processing (V1.0)
 - Standard
 - Standard transmission terms (Float)
 - String functions
 - Timer (Float)
 - Timer (Time) V2.0
 - Visualization blocks (Time) V2.0
 - Visualization Blocks (V6.0)

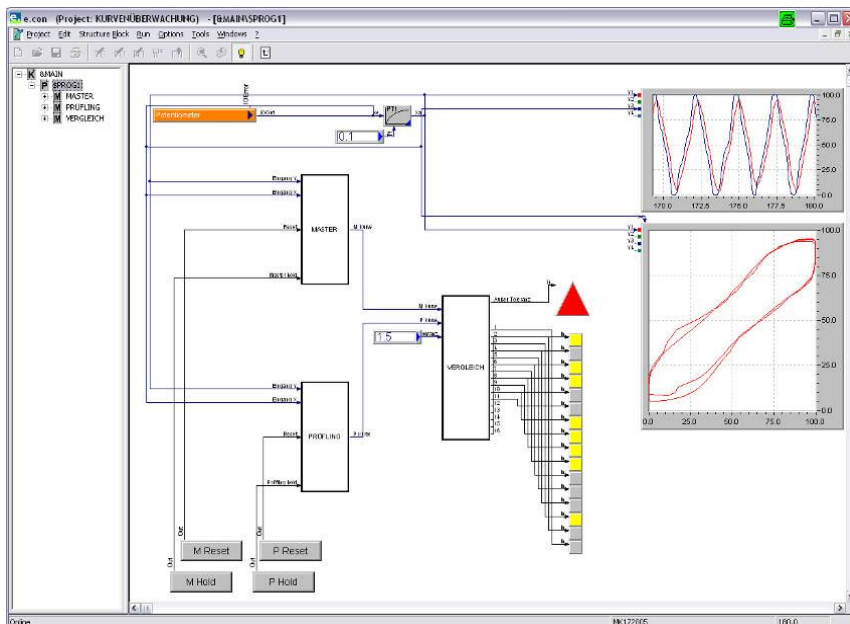

Warm Up Time

All declarations are valid after a warm up time of 45 minutes.

Valid from January 2011. Specification subject to change without notice
DB_Q.raxx_A107-16SL_E_20.docx